

Лоток по умолчанию

Данные объекта

Материалы

рама

Выбрать Правка

В модели

Компоненты

Стили

Метки

Название	Dashes
Непомеченные	По умолчанию
розетка	По умолчанию
потолок	По умолчанию
пол	По умолчанию
остров	По умолчанию

Тени

Сцены

Измерения

Щелкните или перетащите для выбора объектов. Shift = Добавить/Удалить. Ctrl = Добавить. Shift + Ctrl = Удалить.



Измерения

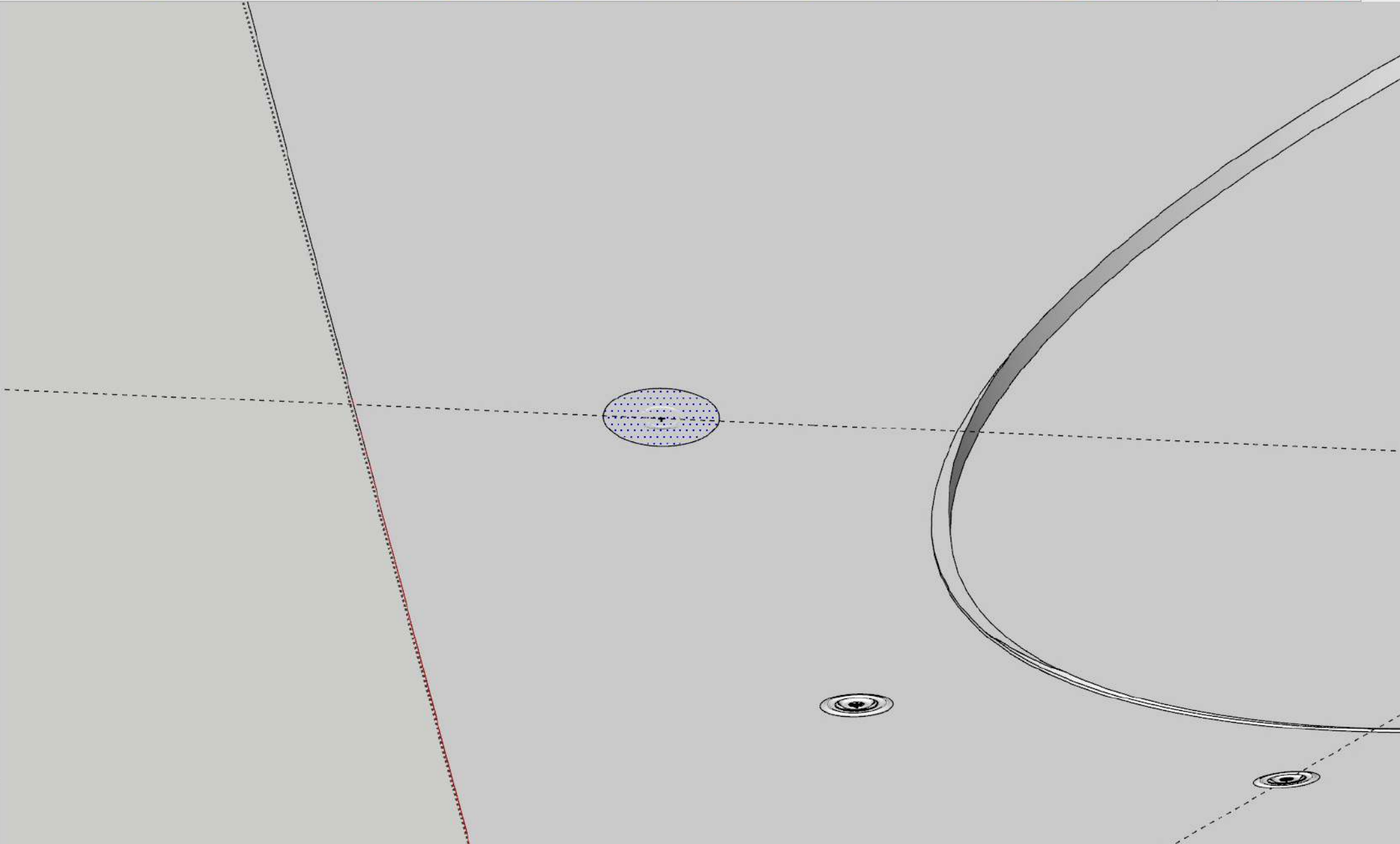

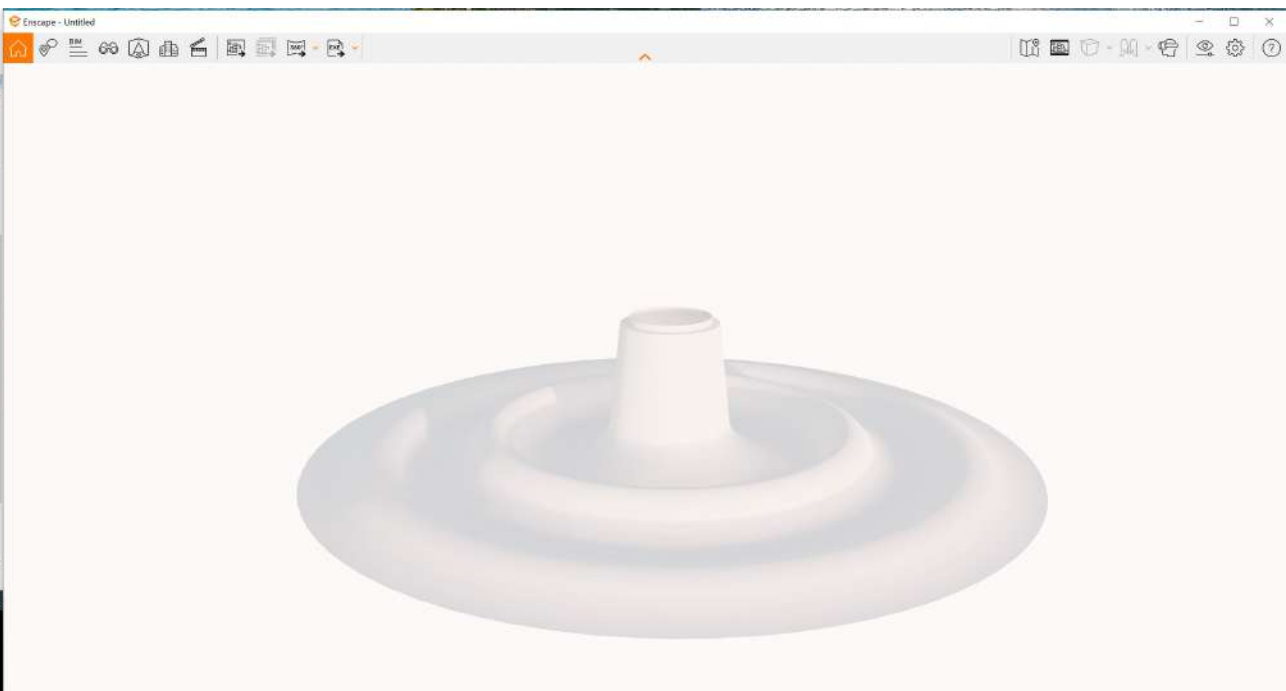
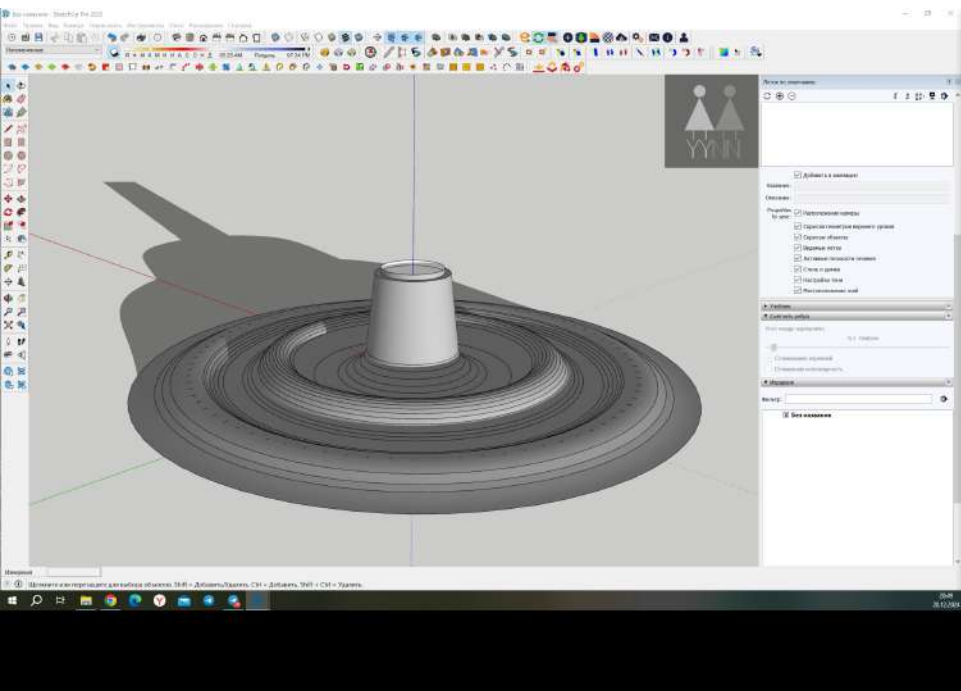

Непомеченные

Я Ф М А М И И А С О Н Д 04:02 AM Полдень 09:05 PM

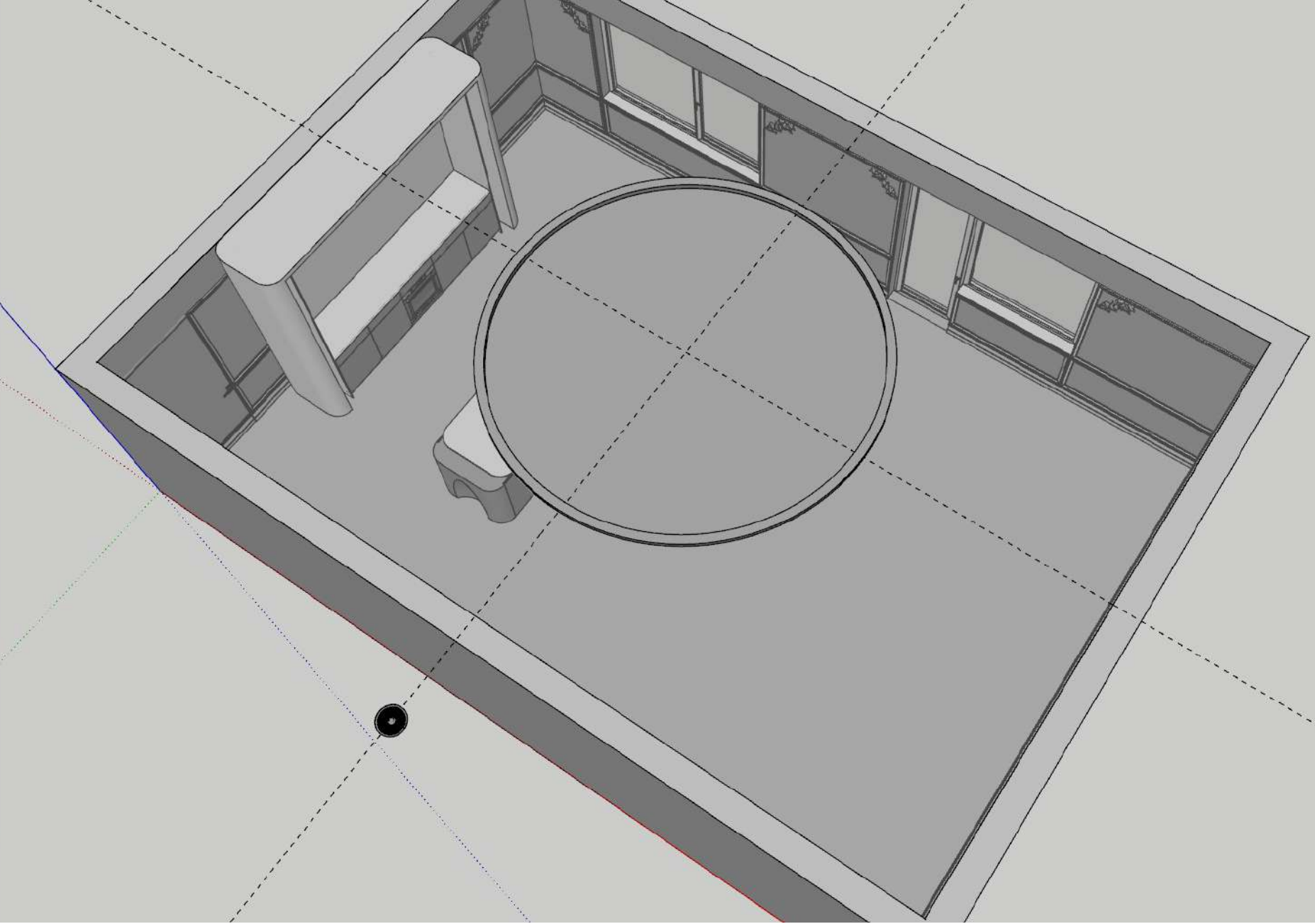

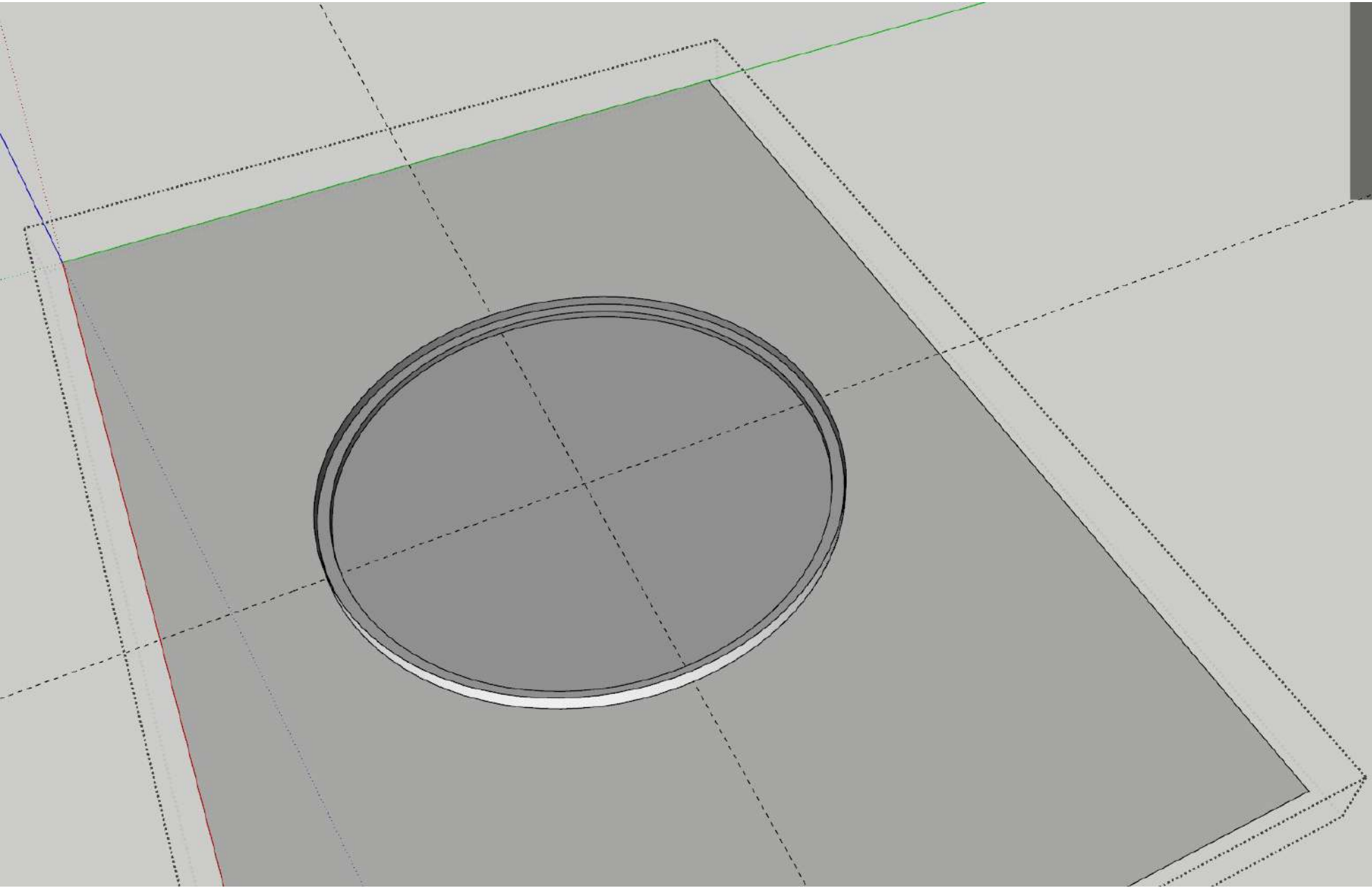
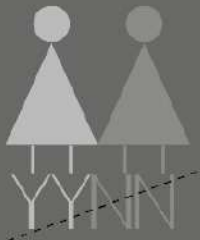

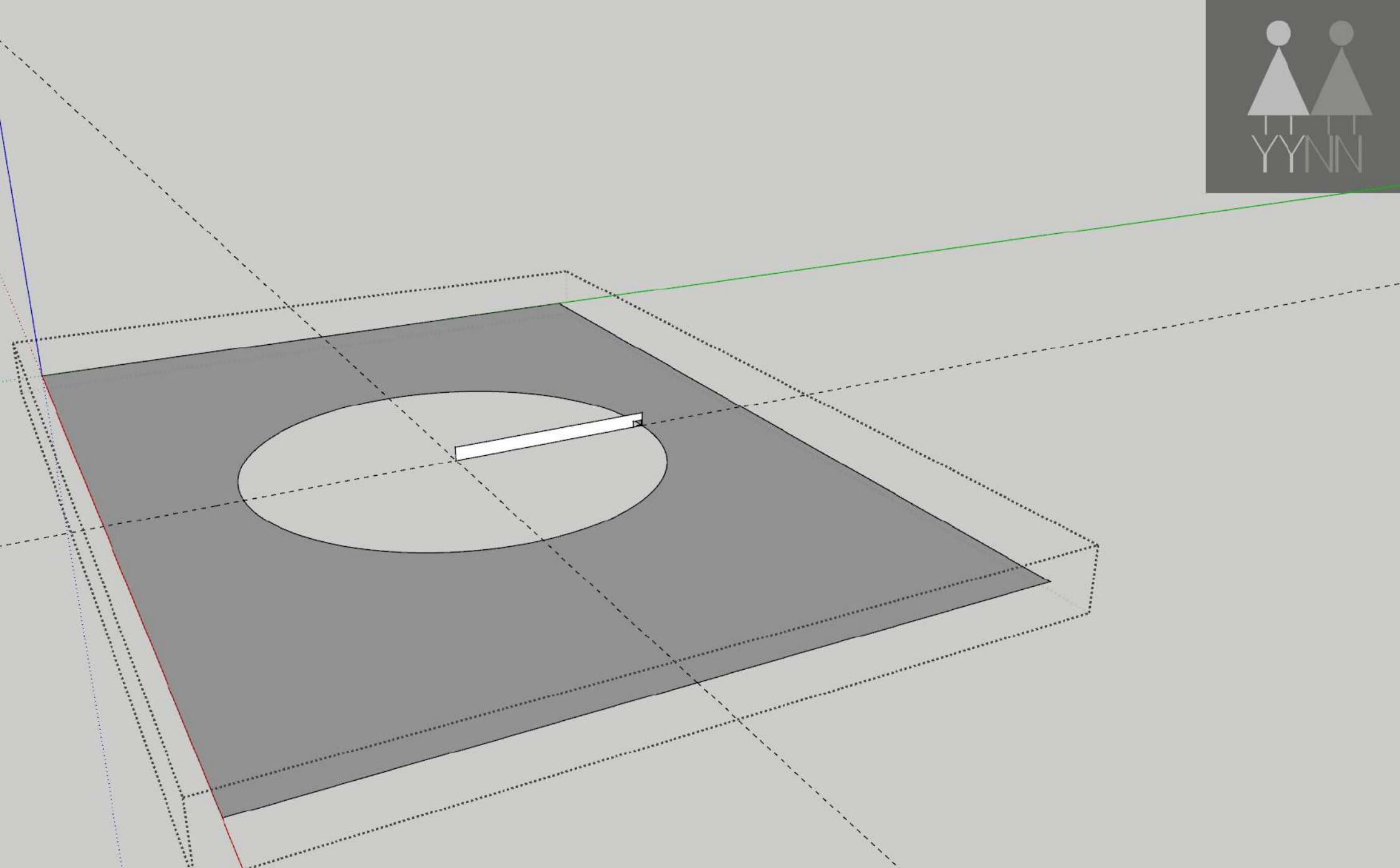

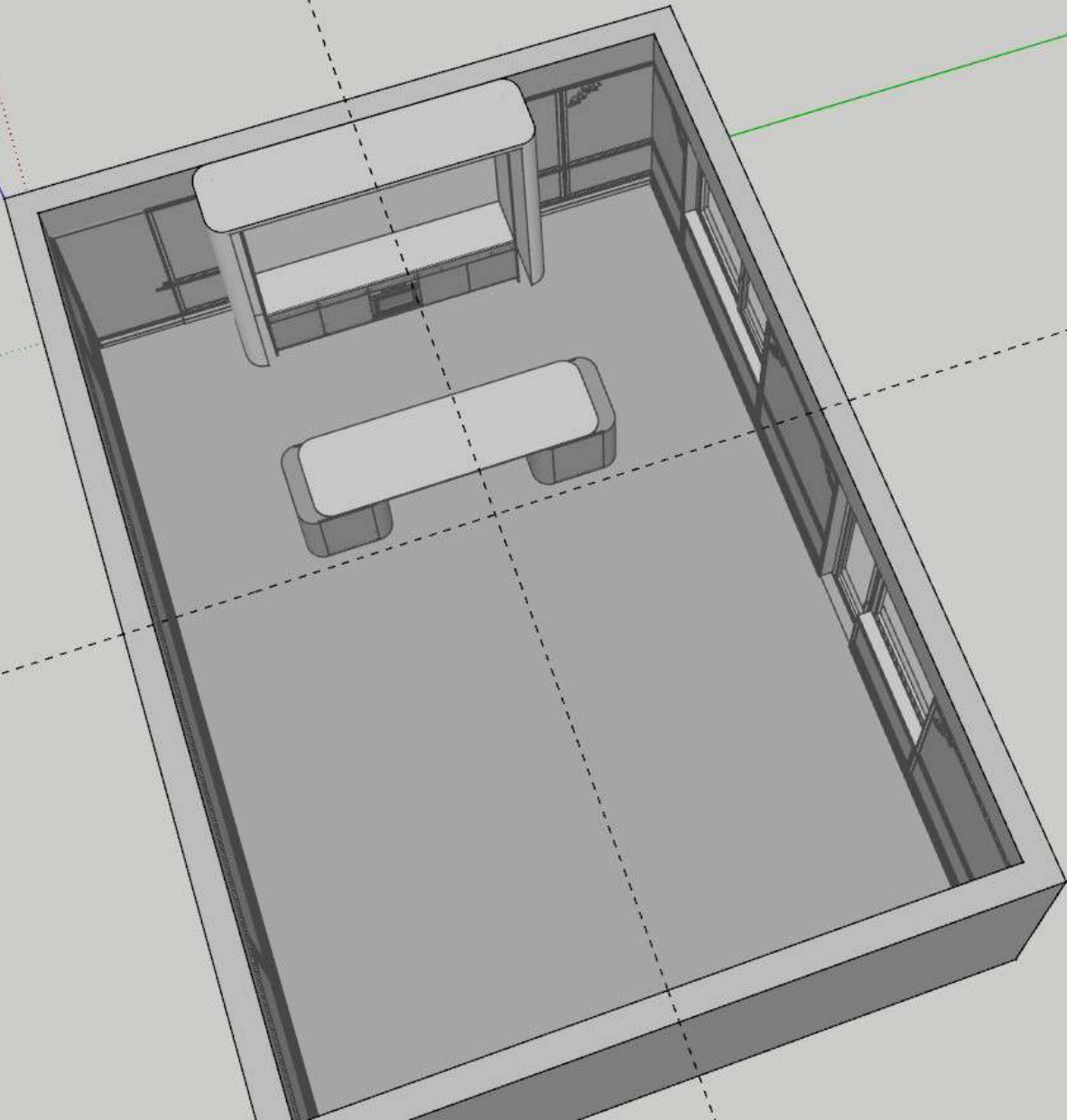
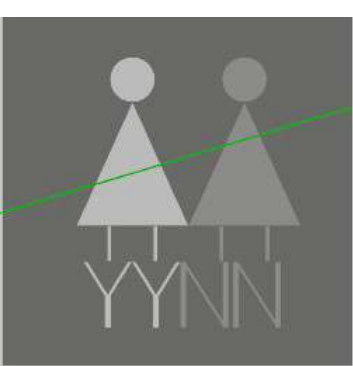

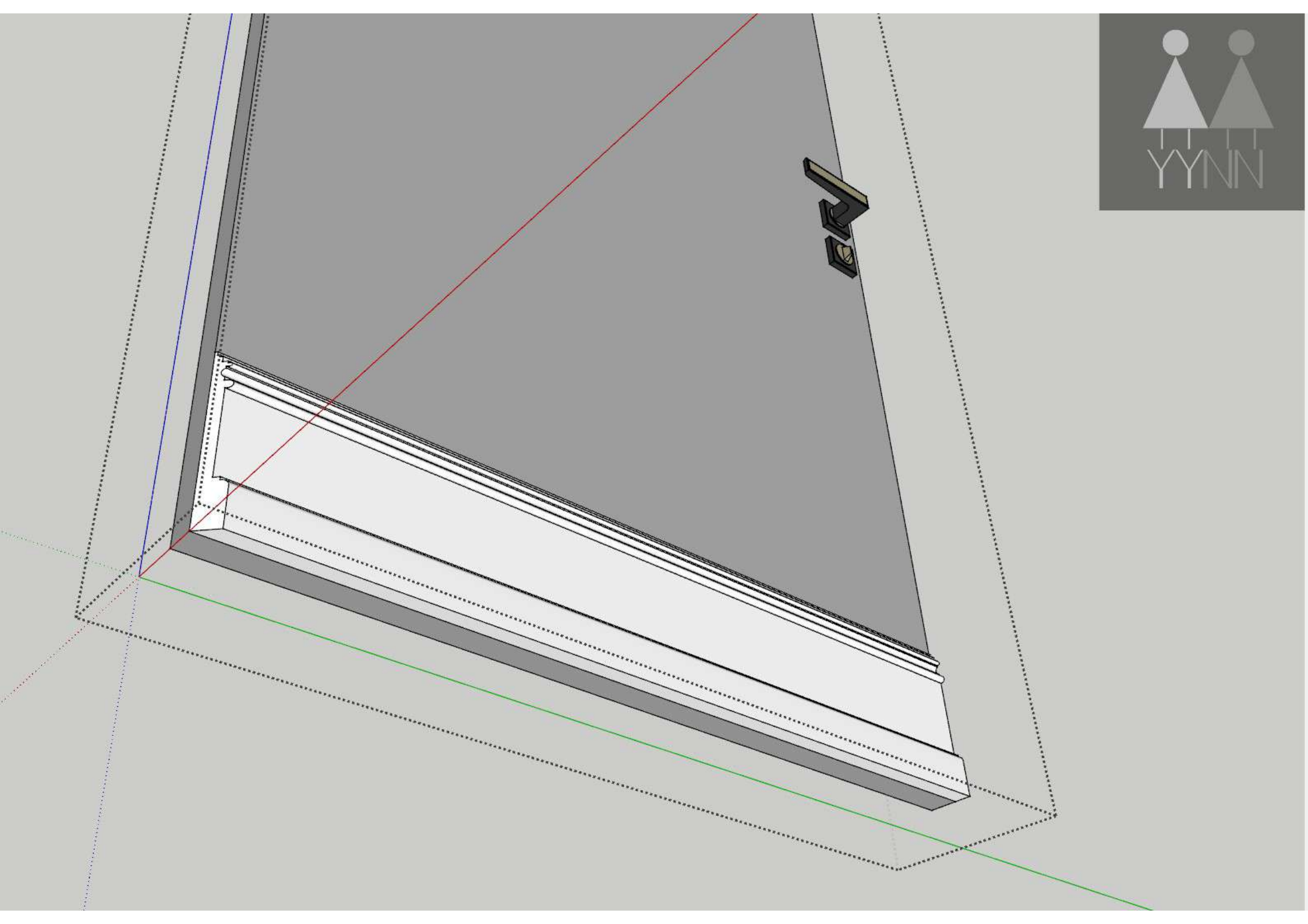

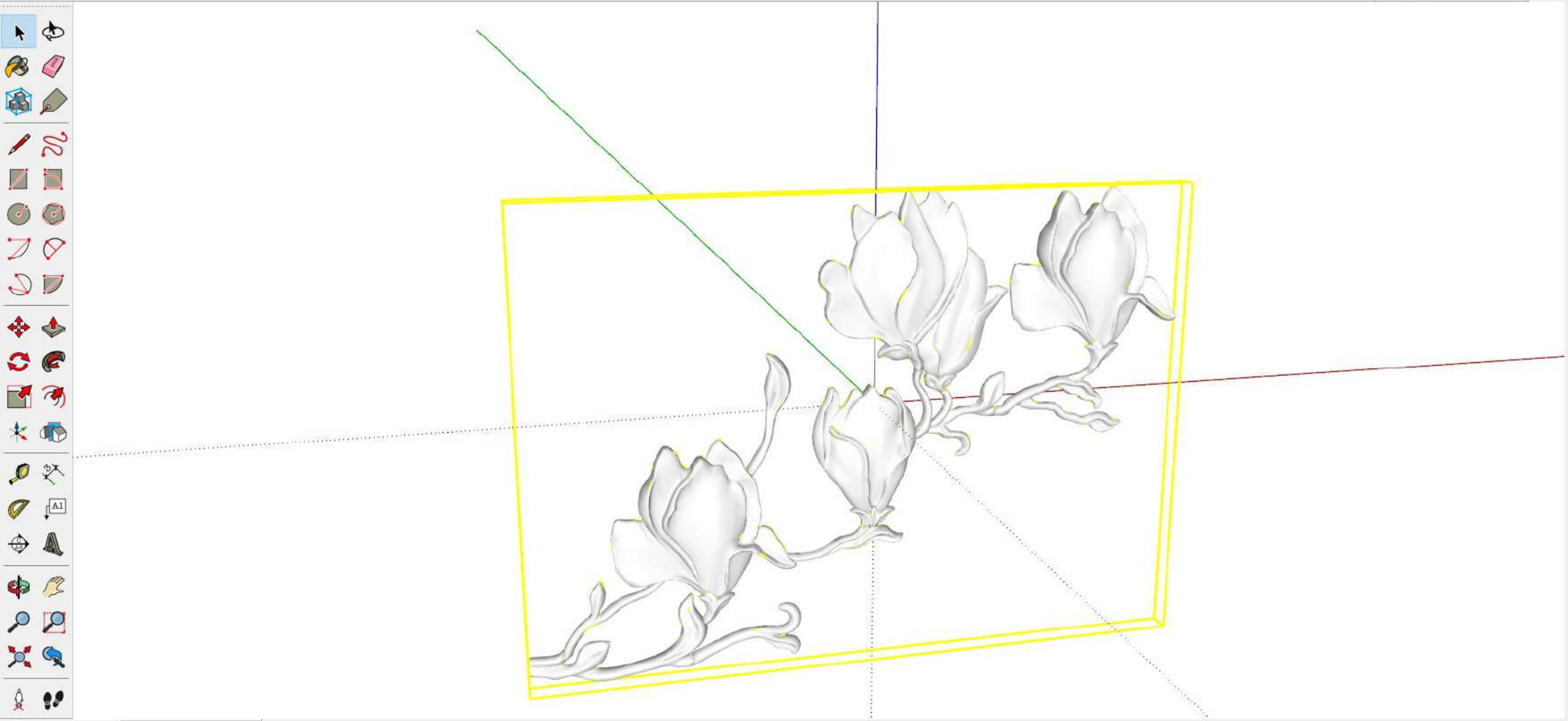



NEW

TRANSMUTE

Show edges

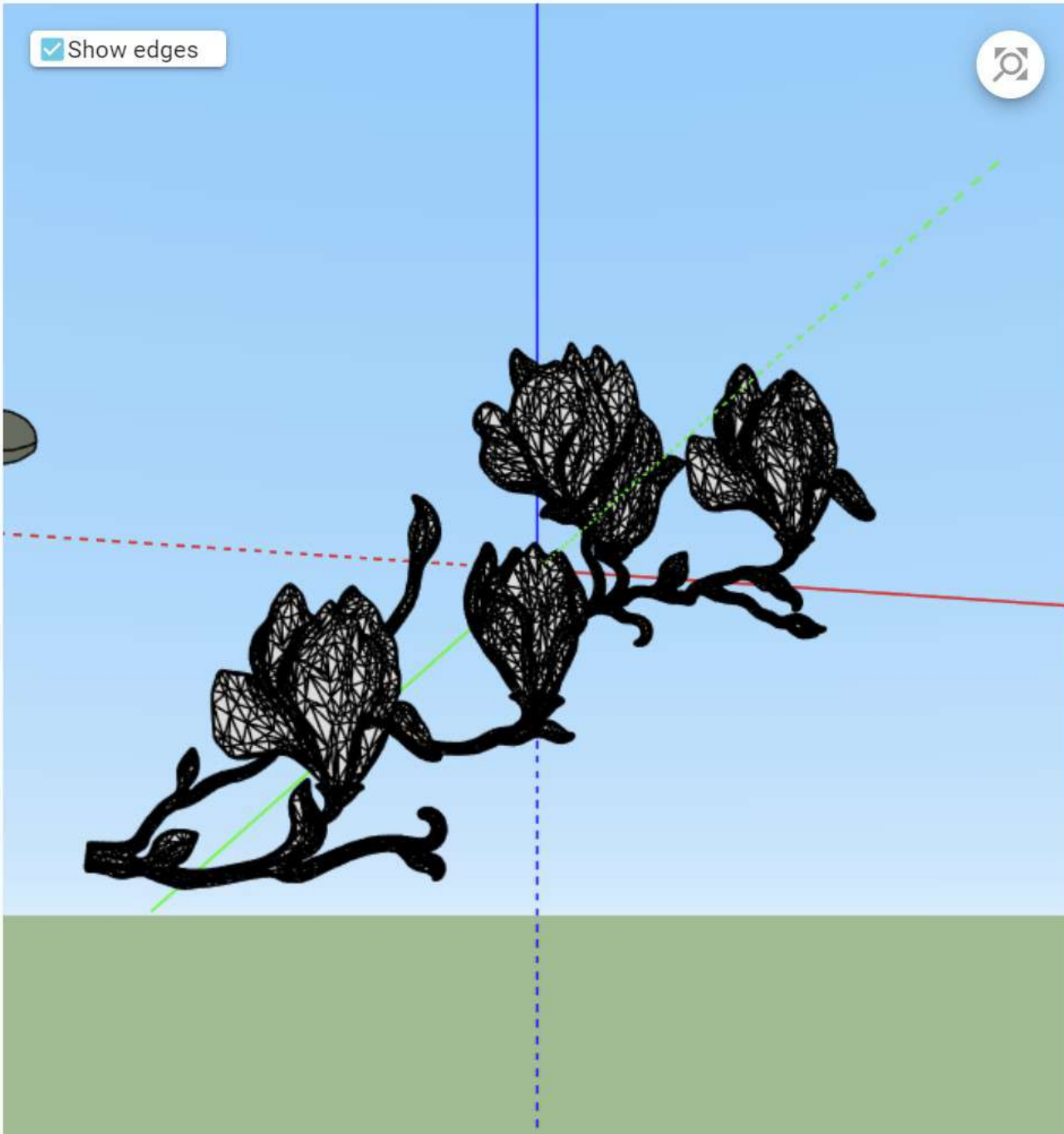

GEOMETRY

MATERIALS

Transformation

- Scale multiplier: 100 %
- Units conversion: mm
- Up axis: +Y
- Origin: Default
- Soften coplanar edges:
- Smooth Angle: 0 °

Mesh simplification

- 27,95 %
- Preserve UV seams:
- Preserve normals:

Stats

20,535 triangles → 14,795

Width (X)	55,031	in	139,78	cm
Depth (Y)	1,712	in	4,349	cm
Height (Z)	39,222	in	99,628	cm

Proxies

- Export as V-Ray proxy:
- Export as Thea proxy:
- Export as Enscape proxy:
- Placeholder: Face skipping
- Face count: 500

